

Heavy-Duty Modular Furniture

Packing Table Assembly

(D-9000, D-9001, D-9005)

Component Parts:

- 1 - Table Top with Frame
- 2 - Table Legs
- 16 - 5/16-18 x 3/4 Hex Screw
- 4 - 3/8-16 x 1-1/2 Stern x 1-11/16 Base Glide

Packing Table Assembly:

1. Place table top on floor with channels facing up.
2. Press leg frame into table top frame so holes line up, as shown.
4. Secure leg frame with bolts supplied in plastic bag on table.
5. Repeat steps 2-4 for second leg assembly.

Table Height Adjustment:

1. Adjustable leg channel on each leg member telescopes out and is notched every inch to make adjustment easy.
 2. To adjust, loosen bolt on leg member and raise adjustable leg to the desired height; secure bolt.
 3. Turn table upright to operating position.
- NOTE: If optional drawer or cabinet has been ordered, secure mounting frame BEFORE putting table in operating position.
4. Minor height adjustments can be made by using the screw-type leveller on each adjustable leg channel or by resetting the telescope leg.

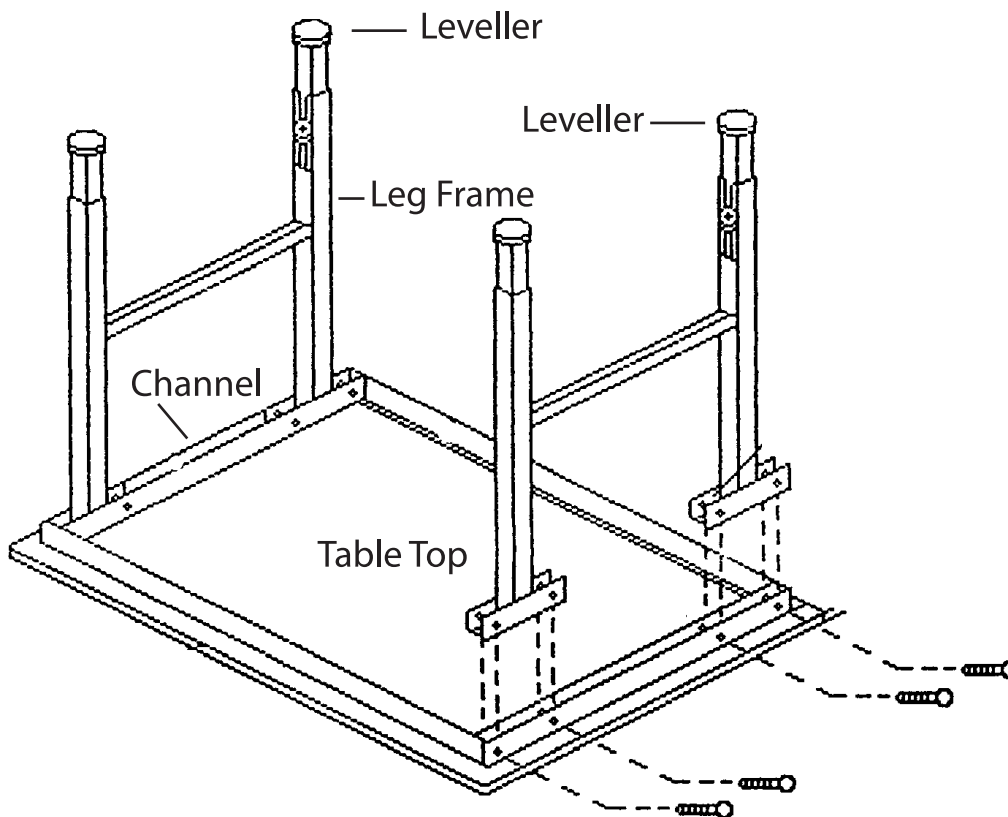

Do not discard packaging material until all contents are located